



Mass Spectrometry

# Stay ahead

with unstoppable confidence

Thermo Scientific TSQ 9610  
Triple Quadrupole GC-MS/MS System

# Unstoppable confidence for analytical testing

To confidently stay ahead, your GC-MS/MS system must deliver ultimate performance while consistently producing trusted quantitative results. That's the reason for the Thermo Scientific™ TSQ™ 9610 Triple Quadrupole GC-MS/MS System. User-centric Thermo Scientific™ NeverVent™ technology, extended-life detector, and intelligent software eliminate unnecessary downtime to maximize your sample throughput and return on investment (ROI). New extended linear dynamic range combined with proven high sensitivity ensures you keep ahead of the toughest regulatory methods and business demands.

Combine the TSQ 9610 Triple Quadrupole GC-MS/MS System with the Thermo Scientific™ TRACE™ 1600 Series Gas Chromatograph (GC) and Thermo Scientific™ AI/AS 1610 Liquid Autosampler to optimize the performance and productivity of your solution.

## Increase instrument uptime

Eliminate unnecessary and unplanned instrument downtime to deliver high-confidence quantitative results, day after day. The TSQ 9610 Triple Quadrupole GC-MS/MS System combines unstoppable robustness with the ability to change the GC column and clean the ion source without interrupting analytical workflows.

## Maximize sample throughput

When high sample throughput is essential, the system delivers results on time and with ease. Automated workflows and simplified operation ensure every user produces consistent results, sample after sample. Extended linear range and rapid selected reaction monitoring (SRM) scanning enable method consolidation so you can analyze more compounds in a single run. When these capabilities are combined with best-in-class uptime and sensitivity, you stay ahead of any productivity demand.

## Realize rapid return on investment

Ensuring your system delivers results as soon as it's installed is necessary to achieving rapid ROI. With built-in intelligence that simplifies instrument set up, analytical methods, and everyday operation, the TSQ 9610 Triple Quadrupole GC-MS/MS System is designed for accelerated deployment. Reduced needs for operator training and faster time to full productivity together with maximum sample throughput provide fast return on your instrument investment.

The TSQ 9610 Triple Quadrupole GC-MS/MS system coupled to the Thermo Scientific™ TRACE™ 1610 gas chromatograph and the TriPlus RSH SMART autosampler

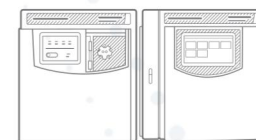

Environmental



Food safety



Petrochemical



Clinical and toxicology



Pharmaceutical

# Unstoppable confidence in uptime for full-time productivity

Unplanned or planned downtime can result in poor asset utilization and reduced sample throughput. The TSQ 9610 Triple Quadrupole GC-MS/MS System features innovations that reduce downtime for routine maintenance while instrument health monitoring assists you in determining when maintenance is needed to avoid unnecessary downtime. As a result, you maximize instrument utilization, sample throughput and ultimate ROI.



## NeverVent technology

Using NeverVent technology with the Vacuum Probe Interlock (VPI) and V-Lock source plug, planned maintenance such as changing column and ion source cleaning can be performed without venting the mass spectrometer, increasing uptime. NeverVent technology is available on both the Thermo Scientific™ ExtractaBrite™ and the Thermo Scientific™ Advanced Electron Ionization (AEI) sources.

If the ExtractaBrite ion source is configured, the VPI can be used to avoid venting when changing between electron ionization (EI) and chemical ionization (CI) modes. If the AEI source is configured, the filament can also be changed without venting.

## ExtractaBrite Ion Source

For over a generation, the ExtractaBrite ion source has provided trusted EI and CI results. The EI ExtractaBrite ion source offers proven robustness and sensitivity that meets regulatory requirements. To adapt to various applications, you can switch between EI and CI modes without breaking vacuum.

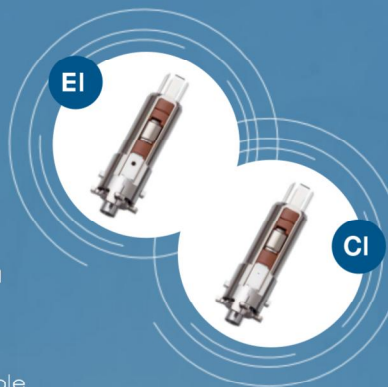

## Advanced Electron Ionization (AEI) Source

The AEI source offers the ultimate in robust EI sensitivity, for reproducible low-level quantitation of target compounds in the most challenging matrices.

## XLXR™ Detector

Standard on every TSQ 9610 Triple Quadrupole GC-MS/MS System, the XLXR detector lasts eight times longer than its predecessor. By extending time between replacement for preventative maintenance, running costs and obstacles to productivity are significantly reduced.

## NeverVent AEI

		Maintenance activity		
		Column change (hrs:mins)	Exchange ion source (hrs:mins)	Replace filaments (hrs:mins) (only available on NV-AEI)
Standard GC-MS	Requires vacuum system venting and pump down operations	4:35	4:00	4:00
NeverVent GC-MS	Venting and pump down not required	00:35	00:05	00:05
NeverVent time savings		87%	98%	98%

Compared to standard GC-MS technology, NeverVent technology offers substantial time savings when typical maintenance activities are performed.

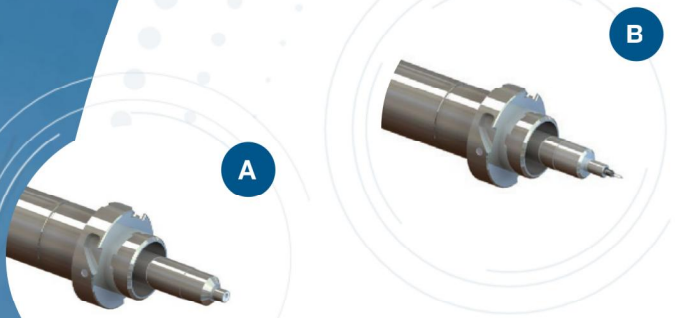

Optional A) Direct Insertion Probe (DIP) and B) Direct Exposure Probe (DEP). The DIP can be used for rapid analysis of solid matrices and features slow volatilization with a heated capillary tube. The DEP features a heating filament for rapid molecular weight confirmation of solids that are dissolved or suspended in a suitable solvent.

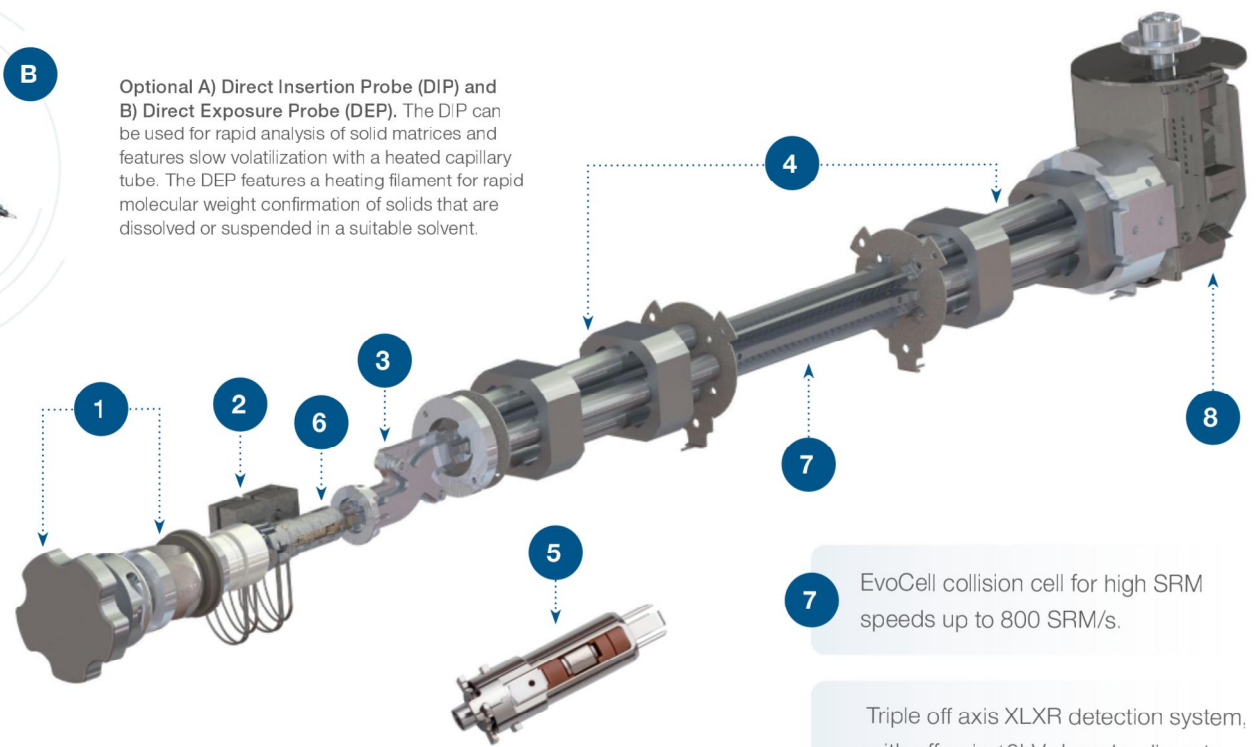

**1** Optional NeverVent AEI source, delivering ultimate sensitivity with interrupted workflows.

**2** Dual source heaters ensuring maximum robustness in heavy matrix.

**3** S-shaped ion guide for off-axis ion optics, eliminating neutral noise.

**4** Solid, homogeneous non-coated, non-heated maintenance-free quadrupoles.

**5** ExtractaBrite ion source, Available with VPI minimizing instrument downtime.

**6** Highly sensitive AEI ion source, featuring a patented RF lens ensuring matrix robustness, that are removable without breaking instrument vacuum with the NeverVent option.

**7** EvoCell collision cell for high SRM speeds up to 800 SRM/s.

**8** Triple off axis XLXR detection system, with off-axis 10kV dynode, discrete dynode electron multiplier, and electrometer with extended linear dynamic range.

Instrument	Ion source	Vent-free source exchange	Vent-free column exchange	Vent-free filament exchange	Compatibility with direct probes	Extended dynamic range and lifetime detector
TSQ 9610 Medium turbo	EI ExtractaBrite source	x	x	x	x	✓
TSQ 9610 AEI	AEI source	x	x	x	x	✓
TSQ 9610 NeverVent AEI	AEI source	✓	✓	✓	x	✓
TSQ 9610 Vacuum probe interlock	EI ExtractaBrite source/OI ExtractaBrite source	✓	✓	x	✓	✓

To address different laboratory needs, the TSQ 9610 Triple Quadrupole GC-MS/MS System is available in four configurations.

# Unstoppable confidence in sample throughput

Maximizing sample throughput is essential to producing results on time. The TSQ 9610 Triple Quadrupole GC-MS/MS System incorporates user-centric innovations that extend service intervals, reduce maintenance, and allow methods consolidation to boost sample throughput while maintaining certainty in quality of results.

## Consolidate methods

Running multiple calibration experiments for a single sample set adds extra time and effort to analytical workflows. The XLXR electron multiplier detector which extends dynamic range twofold compared to the previous design. Extended dynamic range capability enables labs to combine methods, including calibration curve development, allowing analysis of low- and high-concentration compounds in a single run.

Using several methods to analyze a single sample for several compound classes also reduces sample throughput. The instrument's unique EvoCell provides transition speeds of up to 800 SRMs/s without sacrificing sensitivity, allowing use of more SRM transitions and wider SRM acquisition windows. Now, even when analyzing complex matrices, you can consolidate methods and reduce peak losses in case of retention time shifts.

## Intelligent instrument health monitoring

Knowing when to perform planned maintenance ensures sample analysis is not interrupted due to a drop in instrument performance. The TSQ 9610 Triple Quadrupole GC-MS/MS System's instrument health monitoring capability alerts users when to perform maintenance, avoiding unplanned downtime or performance issues requiring sample reanalysis. Instrument health monitoring also facilitates maintenance record keeping so you can manage spare parts effectively to save time and reduce costs.



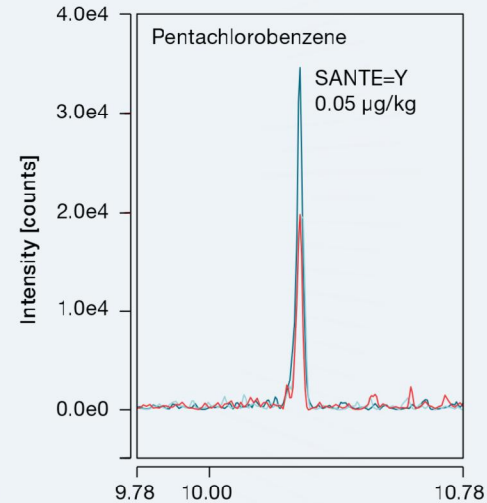
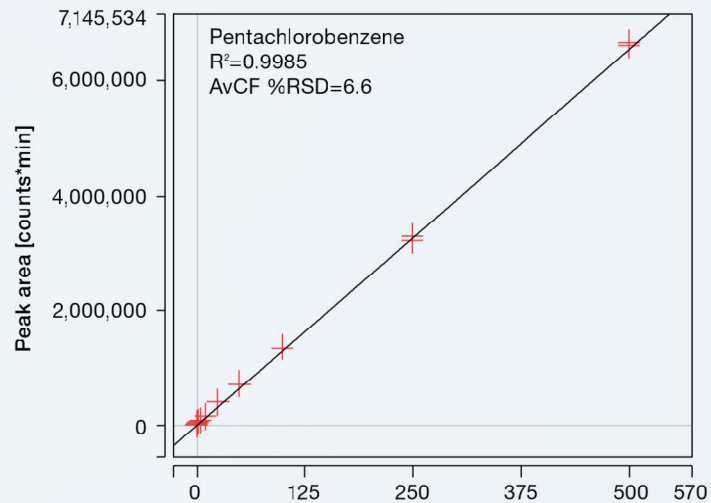
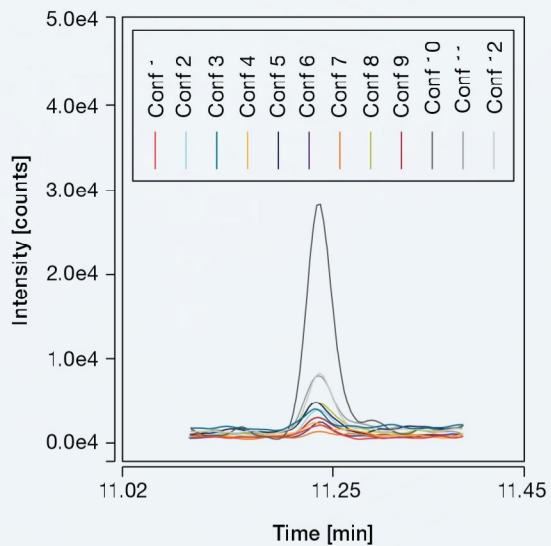

PBDE-209 at 0.5 ppb in environmental extract – 1 µL nonane injected with 12 SRM transitions acquired

Calibration curve of pentachlorobenzene in baby food matrix between 0.05–500 µg/kg with chromatogram showing the lowest calibration point

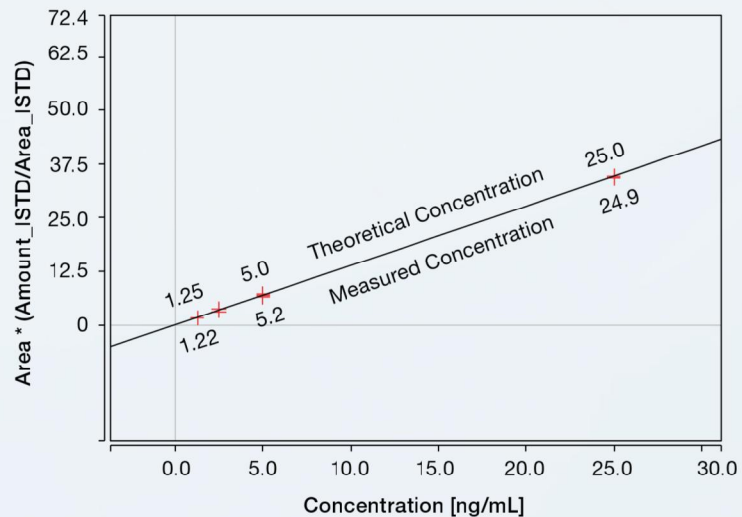
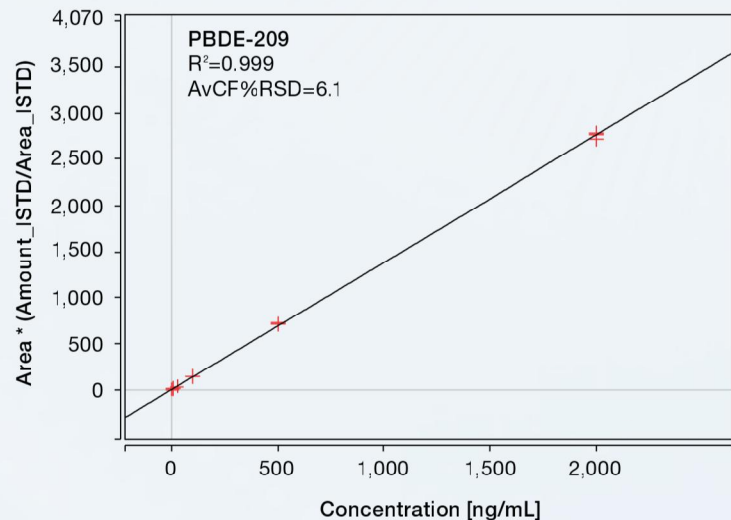

PBDE-209 calibration plot (full range: 1.25–2,000 ng/mL, zoomed detail: 1.25–25.0 ng/mL)

# Unstoppable confidence in your investment

Rapid instrument deployment reduces time to results and revenue generation. That's why the TSQ 9610 Triple Quadrupole GC-MS/MS System includes a comprehensive set of automated tools to provide users with a seamless experience when transitioning from other platforms, developing methods, and analyzing samples. This built-in intelligence reduces operator training needs and time to full productivity for rapid ROI.

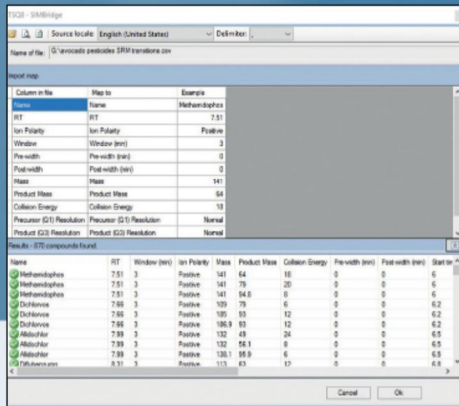

## SIM Bridge

SIM Bridge automatically translates SIM methods exported from other instruments into TSQ 9610 Triple Quadrupole GC-MS/MS System SIM methods. The translated SIM method can be immediately run on the TSQ 9610 Triple Quadrupole GC-MS/MS System, or AutoSRM can be used to translate the SIM information into a powerful SRM method.

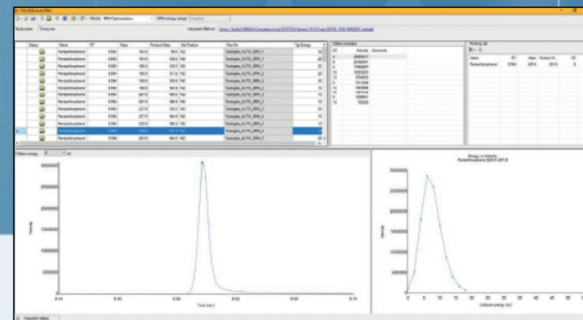

## AutoSRM

AutoSRM makes SRM method development effortless and fast by walking users through the development of fully optimized SIM target ions or SRM transitions in a simple and efficient workflow. If you prefer to start from your current SIM method, SIM Bridge can import the existing method details.

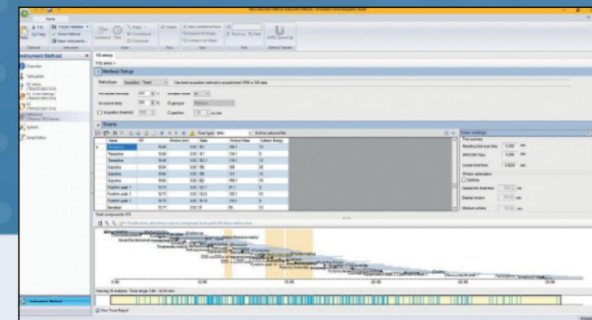

## Timed SRM (t-SRM)

As methods are consolidated and more compounds are added to a single analytical run, managing acquisition windows becomes increasingly complex. The TSQ 9610 Triple Quadrupole GC-MS/MS System eliminates this complexity by automatically optimizing targeting of a particular compound. The analyst simply enters the retention time and the time required to capture the peak, and t-SRM takes care of the rest. T-SRM optimizes compound detection for maximum sensitivity and allows addition of more compounds to a method without compromising performance.



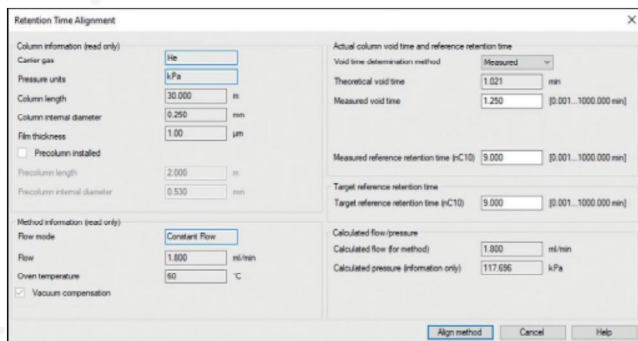

## Retention time alignment

Retention-time shifts due to changing the analytical column or performing maintenance should not result in missed compounds. The RTA tool maintains retention times while running everyday high-throughput GC-MS methods. If the column is changed or trimmed, the user simply provides the new column length and internal diameter or corrected pressure and flow values. RTA then uses the column's measured void time and the retention time of a reference substance to quickly realign the retention times of all the peaks in the chromatograms.

## SmartTune

SmartTune eliminates the complexity associated with tuning, ensuring Thermo Scientific™ TSQ™ instruments are performing at required levels prior to running samples. A simple, guided interface efficiently checks and tunes the system, and intelligently eliminates any unnecessary steps in the process, resulting in faster tuning. If a problem is detected, SmartTune recommends the appropriate corrective action. SmartTune also provides user-customizable targets to facilitate consistency in performance between analytical sequences.

In regulated environments, tuning methods must be included with the analysis for compliance. SmartTune can be operated in-sequence for compliance, method flexibility, and to allow several analyses during one sequence.

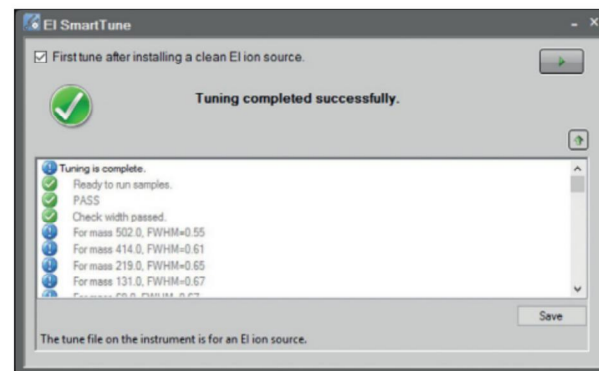

# Unstoppable confidence in quantitative performance

Confidence in quantitation is assured with best-in-class sensitivity, speed and reproducibility delivered consistently day after day. The TSQ 9610 Triple Quadrupole GC-MS/MS System provides high-sensitivity analysis with design innovations such as the ExtractaBrite ion source, highest sensitivity AEI source and EvoCe

## Exceed sensitivity requirements

Laboratories expect their instruments to deliver the sensitivity required to meet the toughest analyses and regulations, today and in the future. When equipped with the ExtractaBrite ion source, the TSQ 9610 Triple Quadrupole GC-MS/MS System can consistently perform low-level quantitative analyses. For ultra-trace quantitation, the AEI source can be chosen to reach attogram-level detection limits, allowing you to confidently exceed regulatory requirements.

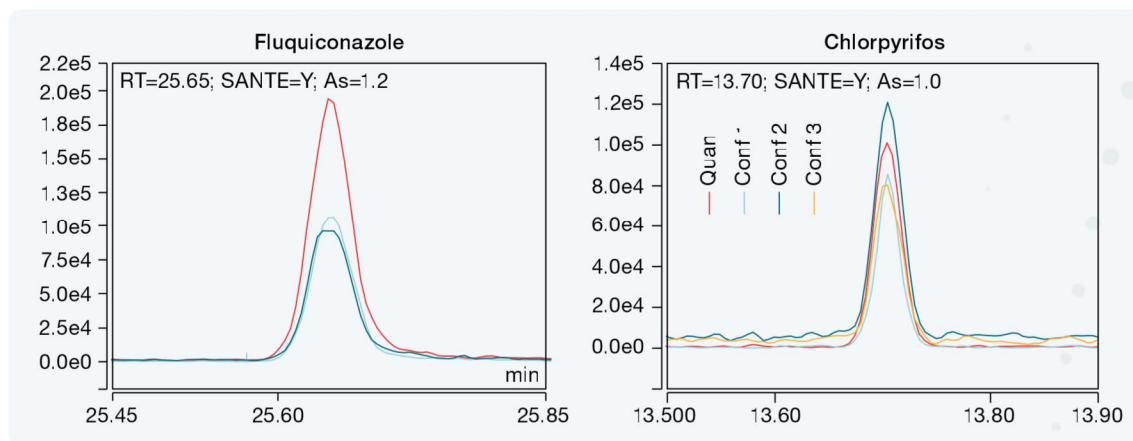

Analysis of fluquiconazole and chlorpyrifos in QuEChERS extracts at 1 ppb

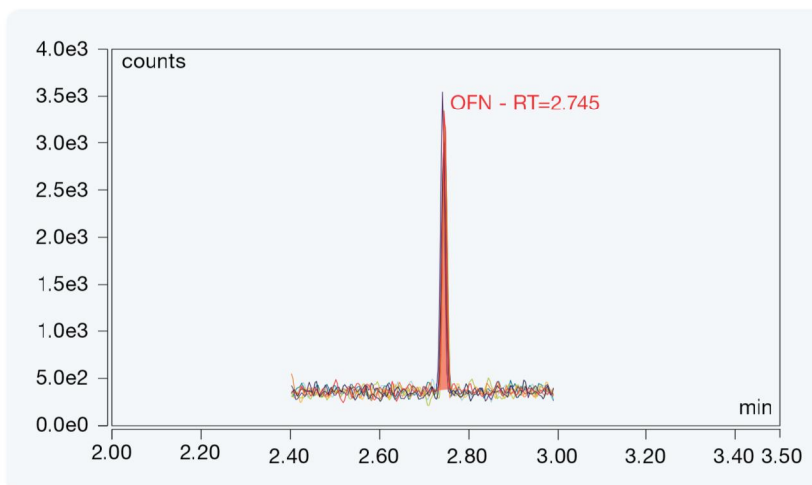

Overlay of 8 consecutive 1 fg on-column OFN injections with %RSD of 4.12% giving an IDL of 0.12 fg

## Obtain consistent results

Being able to meet regulatory limits is not enough. An instrument must produce consistent results at these limits, day after day. In either ion source configuration, the TSQ 9610 Triple Quadrupole GC-MS/MS System produces robust, best-in-class results. Compared to other systems, the instrument can analyze substantially more samples before routine maintenance is needed.

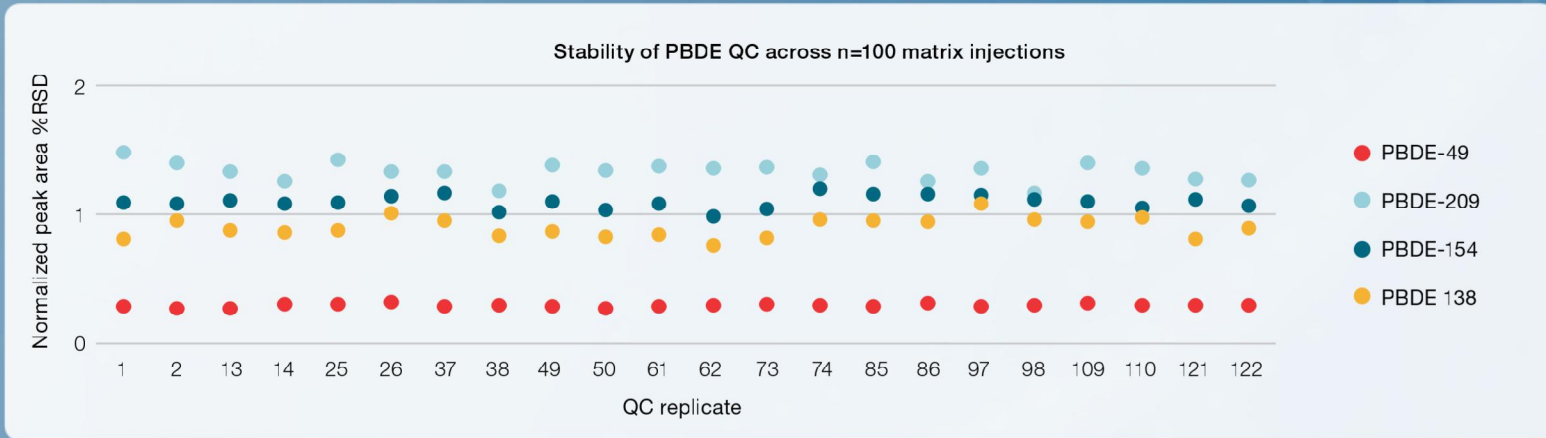

PBDE QC (5–25 ng/mL) normalized peak area %RSD across a sequence of n=100 injections of various environmental and fish oil extracts

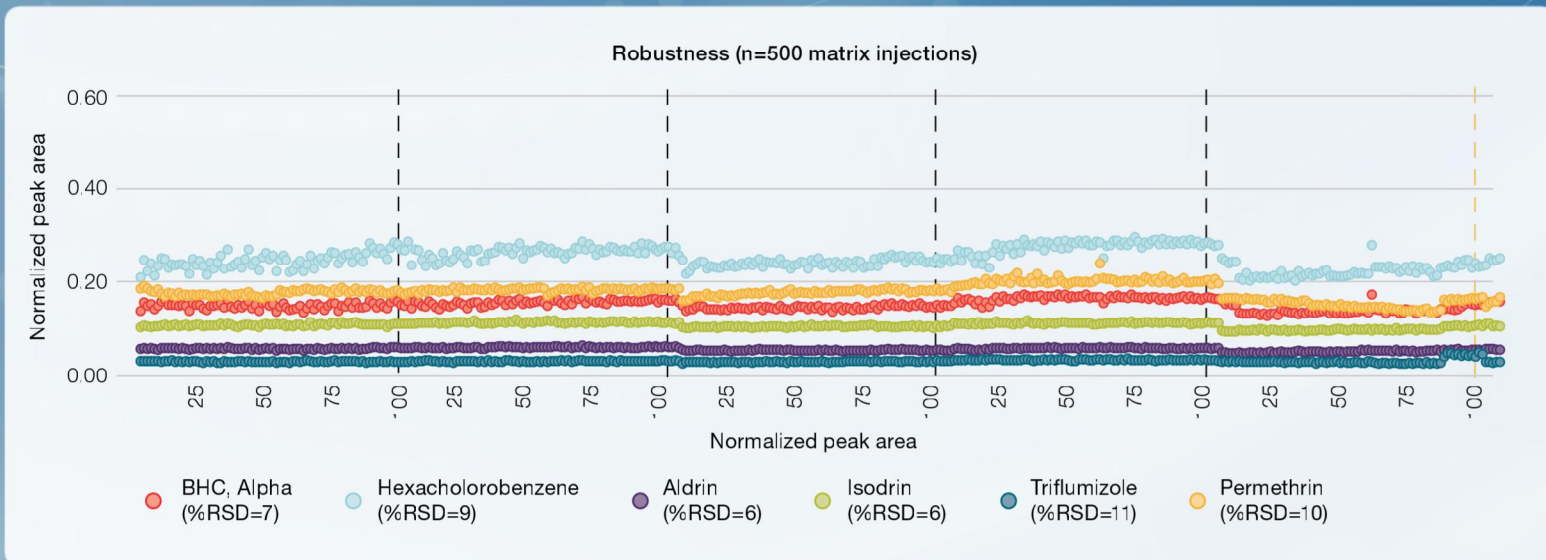

Analysis of 500 consecutive injections of baby food matrix samples spiked at the default MRL (10 µg/kg). Every 100 injections (blue dotted lines) the PTV liner and septum were replaced, approximately 6 cm of the head of the column were trimmed and the SmartTune feature was used to check the instrument status.

# Unstoppable confidence in uptime with a GC always ready to run

Designed for a new level of usability and uptime, the Thermo Scientific™ TRACE™ 1600 Series Gas Chromatograph (GC) delivers measurably more productivity and lower cost of operation. With a unique modular design and plug-and-play injectors and detectors, you have full flexibility to perform maintenance offline and use different configurations on the same GC to make the most of your GC-MS system. When combined with the Thermo Scientific™ AI/AS 1610 Liquid Autosampler, the system provides easy and reliable automated sample injection to meet any sample-throughput demand.

Full range of self-installable injector and detector modules to minimize GC downtime.



High-resolution touchscreen to support daily operations with video instruction that walks through common procedures.

Simplify and speed up column installation with quick, easy, and safe tool-free column connectors with the ability to work comfortably in an illuminated oven.

Instrument health icon is always visible on the GC touchscreen to alert users to maintenance needs.



Easily add robust, unattended sample injection to increase sample throughput, enabling simultaneous analysis into two channels with the Gemini configuration.





### Minimize downtime

Automated GC consumables tracking with alerts minimizes unexpected downtime and waste due to unnecessary replacement. Instrument health is on continuous display on the touchscreen. Tubing-free injectors design allows for easy and quick septum/liner replacement, simplifying routine maintenance operations.



### Perform maintenance offline

Unique Thermo Scientific™ iConnect™ injector and detector modules can be kept as interchangeable spares, allowing analyses to continue while deeper maintenance is performed offline. Simple replacement of self-installable components facilitate as well troubleshooting operations, saving time and money.



### Increase laboratory efficiency

Versatile modular configurability minimizes idle time, maximizing the productive use of your laboratory's GC systems. The suite of iConnect injectors and detectors can be shared among multiple GC systems in numerous configurations without installation costs.



### Save time with robust unattended operation

The slide-in self-aligning AI/AS 1610 Liquid Autosampler provides reliable unattended sample analysis, saving valuable time and increasing productivity while improving data quality with high-precision injections.



### Add robust headspace injection

For volatiles analyses, the Thermo Scientific™ TriPlus™ 500 Headspace (HS) Autosampler offers reliable and robust unattended operation in 12-, 120-, and 240-vial configurations. Valve-and-loop technology and direct column connection ensure highest performance to facilitate compliance in regulated environments. It can be mounted with the AI/AS 1610 Liquid Autosampler for an all-in-one configuration.



### Add the productivity of robotic sample handling

The Thermo Scientific™ TriPlus™ RSH SMART autosampler offers advanced robotic sample handling to extend automation beyond liquid, headspace, and solid phase microextraction (SPME). Your results will benefit from maximized precision and reproducibility, while your laboratory will increase productivity with flexible sample handling and automated sample preparation procedures, such as dilution, internal standard addition, and derivatization workflows.

TriPlus 500 HS Autosampler available in 12-, 120- and 240-vial configurations



The TriPlus RSH SMART Autosampler delivers exceptional precision, flexibility, and productivity with robotic sample handling.

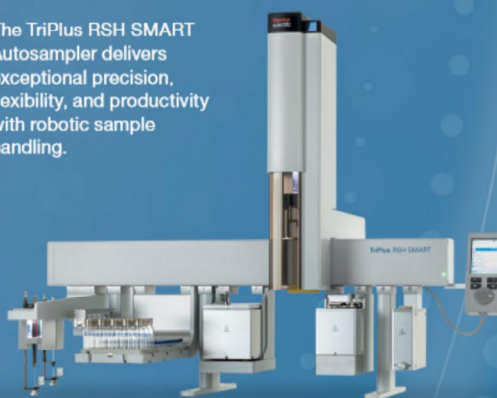

- Flexible liquid sample handling with optimized injection modes and customizable syringe-filling techniques
- Static headspace and ITEX dynamic headspace through high temperature gas-tight syringe with injection volume flexibility
- SPME/SPME Arrow for solvent-free extraction of volatile and semivolatile compounds
- SMART technology for syringes and SPME/SPME Arrow fibers usage tracking

# The right choice for any workflow

The TSQ 9610 Triple Quadrupole GC-MS/MS System can be seamlessly implemented into any laboratory workflow to rapidly produce trusted results. Navigate your most difficult analytical challenges and obtain results on— or even ahead of—time with automated workflows and simplified operation.

## Preserve a clean and safe environment

Analysis of air, water, and soils for the presence of volatile and semivolatile organic contaminants is essential to preserving a clean and safe environment. The sensitivity and robustness of the TSQ 9610 Triple Quadrupole GC-MS/MS System provide high-confidence results with increased uptime and sample throughput. The Trace 1600 Series GC can be coupled with sampling solutions like purge and trap (P&T), thermal desorption (TD), and pyrolysis for the analysis of a variety of environmental samples.

## Ensure food safety

New challenges in food safety analysis emerge every day. The TSQ 9610 Triple Quadrupole GC-MS/MS System offers robust ultra-low-level quantitation of hundreds of contaminants per run. Outstanding reproducibility, ultimate sensitivity, and remarkable speed provide highest confidence in results.



Food safety



Environmental



Petrochemical



Clinical and toxicology

## Detect pharmaceutical product impurities

Undetected impurities in pharmaceutical products can adversely affect their safety and efficacy, and ultimately damage a company's brand reputation. The TSQ 96<sup>®</sup> 0 Triple Quadrupole GC-MS/MS System offers ultra-low sensitivity for the detection of targeted impurities such as nitrosamines, making it easier to guarantee products are safe and effective.

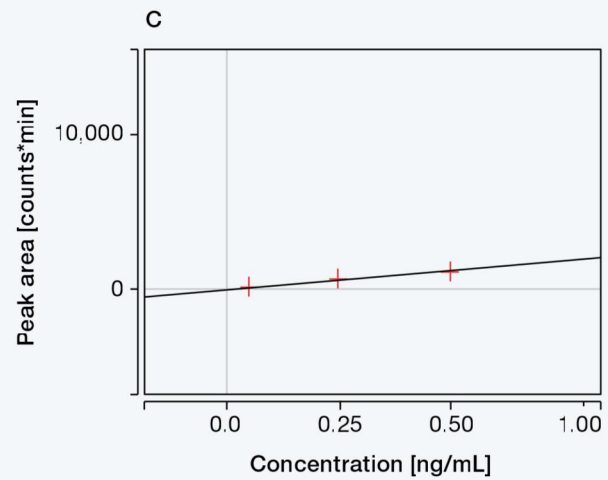
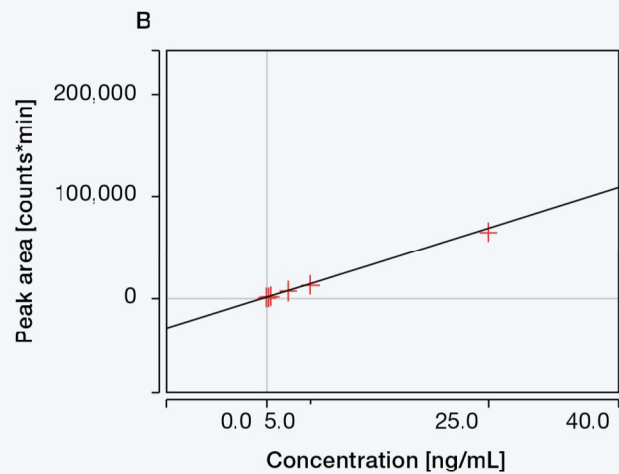
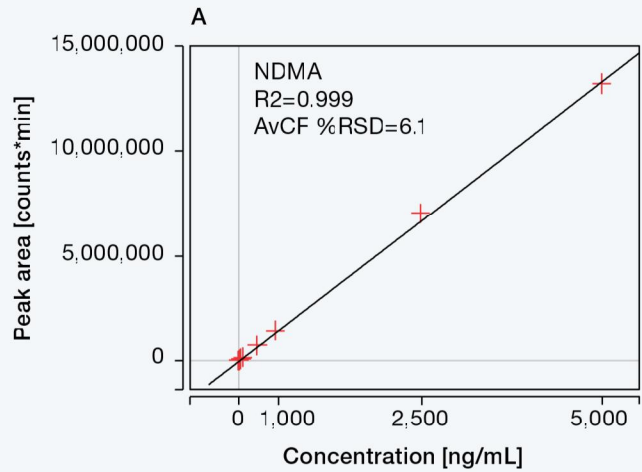

NDMA linear response between 0.05 and 5,000 ng/mL (A), zoomed in calibration plots (B: 0.05–25 ng/mL and C: 0.05–0.5 ng/mL)

## Companion software for the TSQ 9610 Triple Quadrupole GC-MS/MS System

Integrated workflow-driven software, application library, and support streamline your applications and everyday tasks including:

- Instrument optimization and troubleshooting
- Method development and implementation
- Reporting results



### Thermo Scientific™ Chromeleon™ software

Enterprise-level instrument control, data processing, and the ability to address any regulatory requirement.



### Thermo Scientific™ TraceFinder™ software

Comprehensive quantitative workflows for all applications—from method development to report generation.



### AppsLab method library

A comprehensive repository for application-specific methods, data sets, and application notes.



### Service and support

Our global Centers of Excellence, in-your-lab training using your methods, and AppsLab Library of Analytical Applications ensure your success.



## Unstoppable GC-MS technology

Thermo Scientific offers a portfolio of GC-MS systems to address your applications needs. Combined with productivity-enhancing software, these advanced systems enable you to meet or exceed the most stringent requirements for performance, reliability, and value.

### ISQ 7610 Single Quadrupole GC-MS system

For targeted analysis and spectral library matching the Thermo Scientific™ ISQ 7610™ Single Quadrupole GC-MS System. Provides high speed full scan analysis and selected ion monitoring (SIM) for the analysis of compounds in food, environmental and clinical samples.



### Orbitrap Exploris GC mass spectrometers

For targeted or unknown compound identification in complex sample matrices, Thermo Scientific™ Orbitrap™ Exploris™ GC mass spectrometers provide high-resolution accurate-mass (HRAM) data with sub-ppm mass accuracy. Acquire full-scan data for targeted and untargeted screening, confirmation, unknown identification, quantitation, and retrospective analysis.

